

**INSTALLATION, OPERATION, STORAGE AND MAINTENANCE INSTRUCTIONS - J.G. PAPAILIAS , INC. SERIES MSL SIGHT LIGHT FIXTURES**



**SERIES MSL-HI-LED COMPACT LED SIGHT-LIGHT FIXTURE**

**1.0 INTRODUCTION** - Sight lights are simple devices for providing illumination to the inside of a pressure vessel or pipeline through a sight glass or sight flow indicator. Sight lights can be expected to perform reliably if they are properly specified, free of any vibration or shock loadings caused by rapid temperature changes or mechanical impacting and lastly, by using good workmanship in the installation and maintenance of the Sight Light.

All personnel involved in the installation and maintenance of a Sight Light should read and understand all instructions in this manual before attempting installation or maintenance. Personnel should also be familiar with any drawings depicting the Sight Light and have the drawings, if available, on hand during installation or maintenance.

**2.0 RECEIVING INSPECTION** - Papailias Company, Inc., Sight lights meet or exceed all applicable specifications and standards when they are shipped from the factory. Sight lights should be inspected carefully for shipping damage. If damage is evident, do not attempt installation and notify the carrier immediately. If damage is only suspected consult factory before attempting installation.

**3.0 STORAGE & HANDLING** - Sight lights should be carefully stored after inspection. They should be stored in such a manner as to be protected from adjacent equipment, the weather, dust, dirt, and any corrosive atmospheres. The lamp requires extra attention due to the fact that it is easily damaged. It is best to leave all lights in the original packaging

while awaiting installation. Personnel handling Sight lights should have clean hands, free of all dust, dirt, and grease. Sight lights should only be placed on clean surfaces, preferably covered with clean cloth or clean paper.

**4.0 INSTALLATION** - Installation should only be done by qualified personnel who are familiar with Sight lights and local and national electrical codes. All personnel should be read and have a complete understanding of all instructions in this manual and also be familiar with any available drawings depicting the Sight Light.

**4.1 MOUNTING** - Series MSL-100 Sight lights are equipped with an “L” shaped slotted mounting bracket. Place the Series MSL-100 fixture on the Sight glass making certain that the Sight Light gasket is in contact with the outside surface of the lens. Align mounting bracket slot with tapped hole in the Sight glass and fasten with socket head cap screw provided as shown in Figure 1.

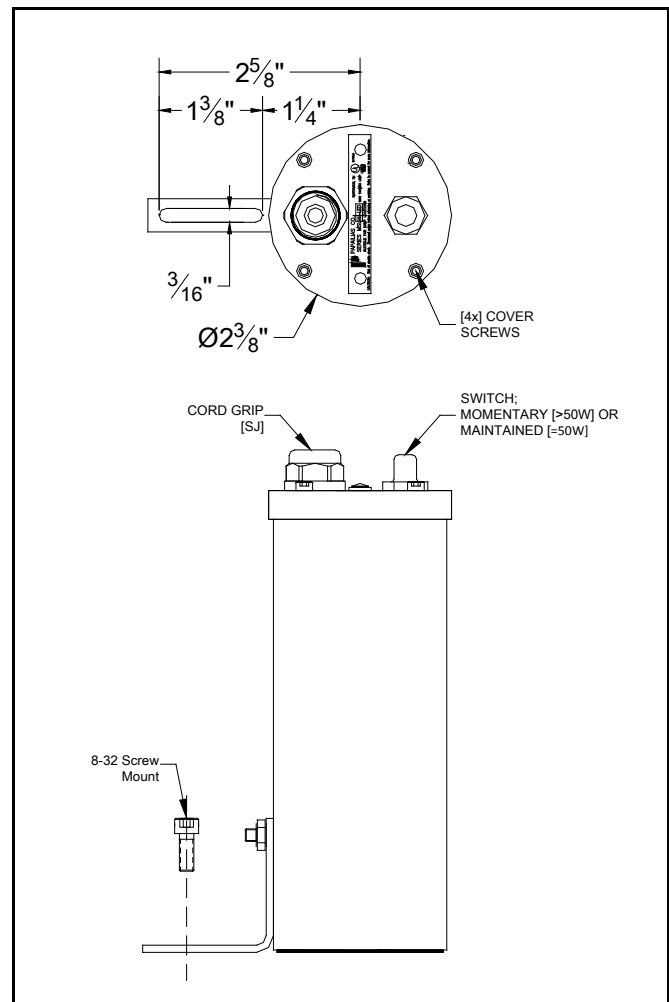

**MSL MOUNTING [FIGURE 1]**

## Installation, Operation, Storage & Maintenance Instructions for Series MSL Compact Light Fixture

**5.2 WIRING** - Before commencing work or wiring, installation personnel should check with the site Electrical Engineer, a licensed electrician or local Electrical Inspector or other such supervisory personnel to determine the type and size of the connection wire required and that the circuit receiving the Sight Light is of an adequate rating. Various versions of the Series MSL-100 and MSL-HI-LED are rated for 115V AC, 230VAC or 24VDC (halogen only). If you are unsure voltage please cease installation and consult the factory.

**CAUTION: BEFORE STARTING ANY WIRING, MAKE CERTAIN THE ELECTRICAL CIRCUIT IS DEAD AND THAT IT CAN'T BE INADVERTENTLY ACTIVATED DURING WIRING OF SIGHT LIGHT.**

Wiring of the Series MSL Sight Light is accomplished by loosening the 4 top socket head cap-screws and removing the cover as shown in Figure 2. Loosen hub of wire entrance fitting and feed sufficient wire through gland for working. Connect wires as shown in Figure 2 using wire nuts or crimp-on butt connectors. Ground should be affixed to the cover using the tapped hole provided.

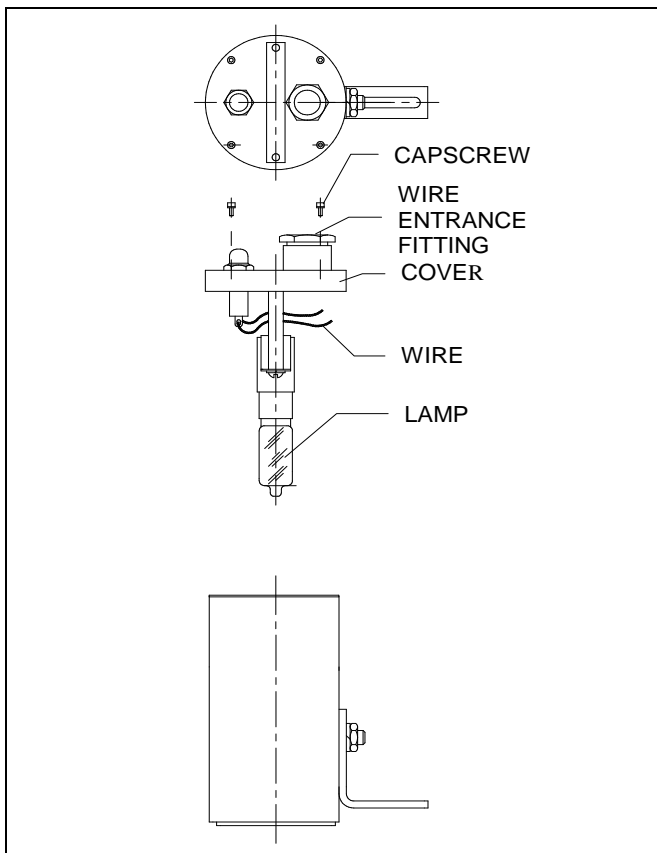

**MSL WIRING [FIGURE 2]**

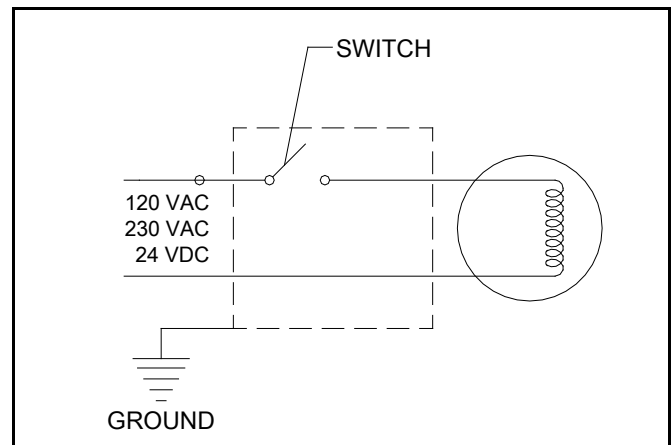

**MSL WIRING [FIGURE 3]**

**WARNING: DO NOT OPERATE THE SIGHT LIGHT WITHOUT HAVING THE GROUND WIRE CONNECTED. PROPER GROUNDING OF THE SIGHT LIGHT IS ESSENTIAL FOR SAFE OPERATION AND USE. UNGROUNDED FAULTY SIGHT LIGHTS CAN CAUSE ELECTROCUTION.**

Upon completion of making all connections, including the ground, replace cover and energize the circuit.

Model	Watts	Input Voltage
MSL-100-00	100	115/120 VAC
MSL-100-01	100	220/240 VAC
MSL-100-02	50	115/120 VAC
MSL-100-03	50	220/240 VAC
MSL-100-04	20	24 VDC
MSL-HI-LED-01	5 [100W Equivalent]	115/120 VAC
MSL-HI-LED-02	5 [100W Equivalent]	220/240 VAC

### 6.0 START-UP

#### 6.1 PRE-OPERATIONAL EXAMINATION

- a. Verify that all installation procedures have been followed and completed.
- b. Check mounting fasteners to be certain Sight Light is held rigidly to the Sight glass.
- c. Examine wire connections for broken insulation and permanency.

## Installation, Operation, Storage & Maintenance Instructions for Series MSL Compact Light Fixture

**7.0 OPERATION** - The J.G. Papailias Co, Inc., Series MSL-100 Sight Light is simple devices designed to provide a means to illuminate the inside of a pressure vessel or pipe through a Sight Glass or Sight Flow Indicator. MSL light fixtures are equipped with either a momentary push button switch or on/off toggle.

To operate the momentary push button, depress and hold button to energize the Sight Light. Upon release of the button, switch springs to the off position to reduce heat build-up and extend lamp life.

For the on/off toggle simply flip the toggle to one side to energize and the opposite to extinguish the lamp.

Lastly, although Sight Glasses and Sight Light are simple devices and will provide trouble free operation provided they are installed properly. It is also important that the Sight Light is not located in areas where objects may be dropped, thrown or generally allowed to come in contact with it. The Sight Light should also be protected from vibration and thermal shock which could be a result of exposure to cold air blasts or cold water rinse. It is recommended Personnel using a Sight Light also use safety glasses which meet industrial safety standards.

**8.0 MAINTENANCE** - The only maintenance required on a Series MSL100 or MSL-HI-LED Sight Light is the occasional need to replace the lamp or HI-LED Light Engine. Replacement lamps or HI-LED light engines may be purchased from the J.G. Papailias Company. To avoid any inconvenience, it is recommended that end user keep one spare lamp for each Sight Light in service.

### 8.1 RE-LAMPING THE SERIES MSL-100 [HALOGEN]:

**CAUTION: BEFORE STARTING RE-LAMPING, MAKE CERTAIN THE ELECTRICAL CIRCUIT IS DEAD AND THAT IT CANNOT BE INADVERTENTLY MADE ACTIVE DURING RE-LAMPING OF THE SIGHT LIGHT.**

To re-lamp the Series MSL-100 Sight Light loosen the 4 top socket head capscrews and lift cover assembly from housing as shown in Figure 2. Cover assembly contains socket and lamp.

For To remove, push lamp in slightly and rotate counterclockwise until lamp springs from socket and properly disengaged

Remove replacement lamp from box in which it came and separate from protective wrapping. DO NOT touch any part of lamp with bare fingers as this will shorten the lamp life. Wrap lamp with paper wrapper provided by manufacturer. Install new lamp by aligning pins on sides of lamp base with slots in socket. Push lamp into socket as far as it will go and rotate clockwise until hitting stop. Carefully lower cover assembly into housing and refasten.

### 8.2 RE-LAMPING THE SERIES MSL-HI-LED [LED]:

**CAUTION: BEFORE STARTING RE-LAMPING, MAKE CERTAIN THE ELECTRICAL CIRCUIT IS DEAD AND THAT IT CANNOT BE INADVERTENTLY MADE ACTIVE DURING RE-LAMPING OF THE SIGHT LIGHT.**

To re-lamp the Series MSL-HI-LED Sight Light loosen the 4 top socket head capscrews and lift cover assembly from housing as shown in Figure 2. Cover assembly contains socket and lamp. Remove and discard entire HI-LED Light Engine are replace with OEM replacement.

### 9.0 REPLACEMENT LAMPS\*:

Model	Watts	Input Voltage	Part Number
MSL-100-00	100	115 VAC	SP-MSL-100-115
MSL-100-01	100	230 VAC	SP-MSL-100-230
MSL-100-02	50	115 VAC	SP-MSL-50-115
MSL-100-03	50	230 VAC	SP-MSL-50-230
MSL-100-04	20	24 VDC	SP-MSL-20-24
MSL-HI-LED-01	5	115 VAC	SP-HI-LED-00
MSL-HI-LED-02	5	230 VAC	SP-HI-LED-01

\*Replacement using NON-OEM parts may invalidate the UL listing